

# Countertop Baby Changing Station Recessed Mount

KB112-01RE

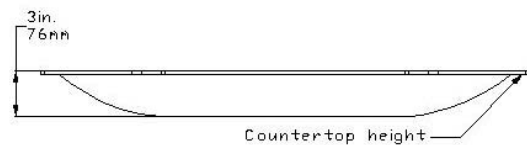
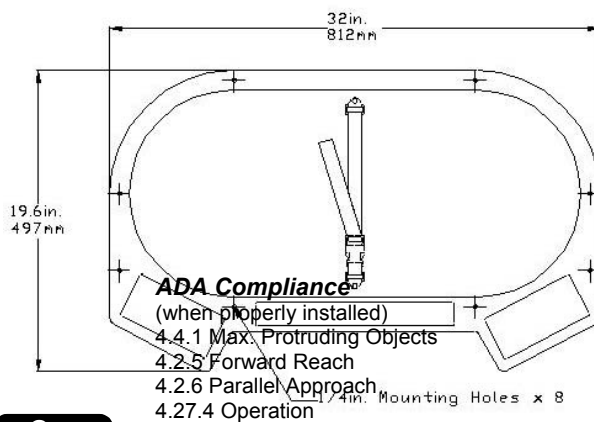

**NOTES:**

Constructed of thermoformed high-density polyethylene. Mounting instructions and hardware included. Graphics include pictograms and messages in six languages. Contoured changing surface comes complete with nylon safety straps.

**OPERATION:**

For use in restrooms where counter space is more abundant than wall space. High-density polyethylene has no sharp corners, is easy to clean and resists odors and bacterial growth.

**Warning:** To insure that the unit supports the intended loads, baby changing stations must be properly installed according to the manufacturer's instructions.

#### INSTALLATION:

To insure proper installation and compliance with building codes, it is recommended that a qualified person or carpenter perform the installation of the unit.

##### Drilling holes and mounting the station:

1. Remove the station from the shipping container and check for any freight damage. Remove the counter cutout template. Identify the best location for installing the baby changing station.
2. Position the front edge of the template approximately 3" (76 mm) from the edge of the counter. Trace the cutout template shape onto the counter top. Cut out the oval opening in the counter top.
3. Place the changing station into the cutout hole, mark the screw hole locations, and drill ten 1/4" (6.5 mm) diameter by 3/4" (19 mm) deep holes.
4. Install a 2" x 4" wooden beam support 3" (76 mm) beneath the counter top surface, centered.
5. Apply a suitable water sealant, such as silicone, around the bottom edge of the changing station, then set unit into recess in countertop. Fasten unit to counter top with supplied screws.

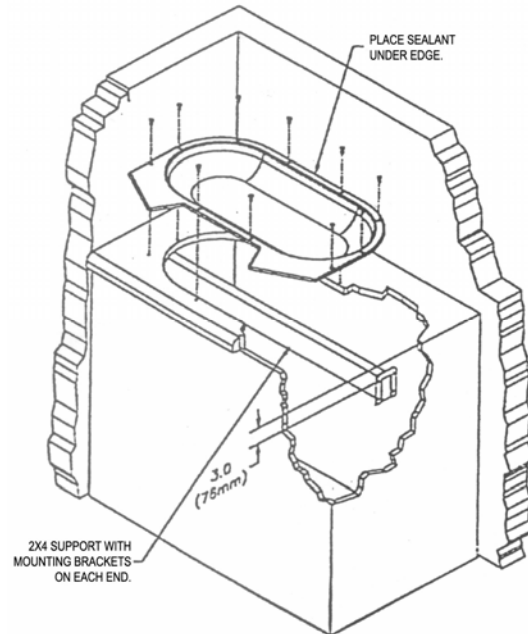

#### Caution:

Drill carefully through ceramic tile and other hard counter top materials.

#### SPECIFICATION:

Baby changing station shall be durable, high impact polyethylene body. Design of unit shall be counter recessed mounted. Bed shall have smooth concave changing area with a nylon safety strap and universal instruction graphics. Manufacturer's service and parts manual shall be provided to the building owner/manager upon completion of project. The unit shall be backed by a 5-year manufacturers limited warranty and manufactured in the U.S.A.